

# SOUTHERN HOIST SERVICES

Unit A, Culverlands Corner, Winchester Road,  
Shedfield, Southampton, Hants. SO32 2JF

Tel: (01329) 833223 Fax: (01329) 833683  
E-mail: sales@southernhoists.co.uk www.southernhoists.co.uk

## GEDA 1200ZZP SPECIAL LK RACK & PINION TRANSPORT PLATFORM



A versatile single mast rack and pinion transport platform, offering a full width c-gated cage.

The hoist can either be used as materials only at 24m/min, or with the addition of a roof piece, it can be used to transport personnel at a speed of 12m/min.

An added bonus is the low pull value of the tie, which allows the unit to be tied to a designed scaffold with ease.

Each unit is equipped with an overload sensor and side protection rails on the unloading ramp for safety.

SHS are proud to have developed this model with the manufacturer to fulfil the increasing need for easy loading on site

Shown above in transport platform mode –  
overhead protection removed in goods only mode

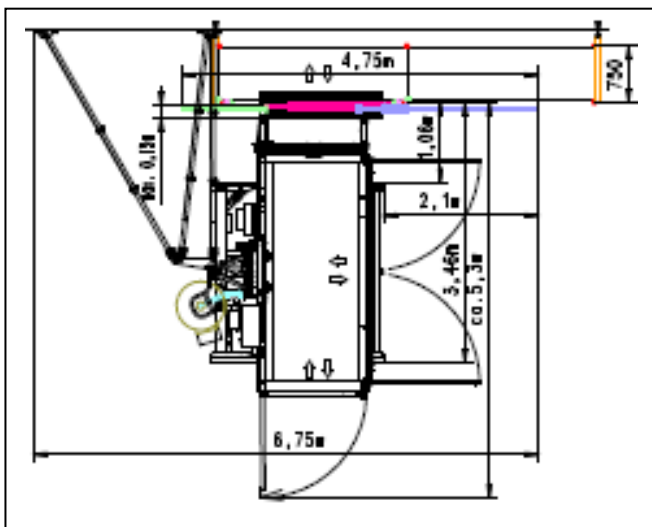

### TECHNICAL SPECIFICATIONS

Max carrying capacity	1500kg / 7 person 3.1 x 1.4m cage
Average lifting speed	Material mode - 24m/min Passenger mode – 12m/min
Power requirement	3 phase and neutral 415 volt 32 amp (pp)
Max. working height	100m
Platform dimensions	Dependant upon platform see opposite
Weight of base unit	1564kg
Weight of mast section	79kg