

SOUTHERN HOIST SERVICES

Unit A, Culverlands Corner, Winchester Road,
Shedfield, Southampton, Hants. SO32 2JF

Tel: (01329) 833223 Fax: (01329) 833683
E-mail: sales@southernhoists.co.uk www.southernhoists.co.uk

GEDA 300Z **RACK & PINION GOODS ONLY HOIST**

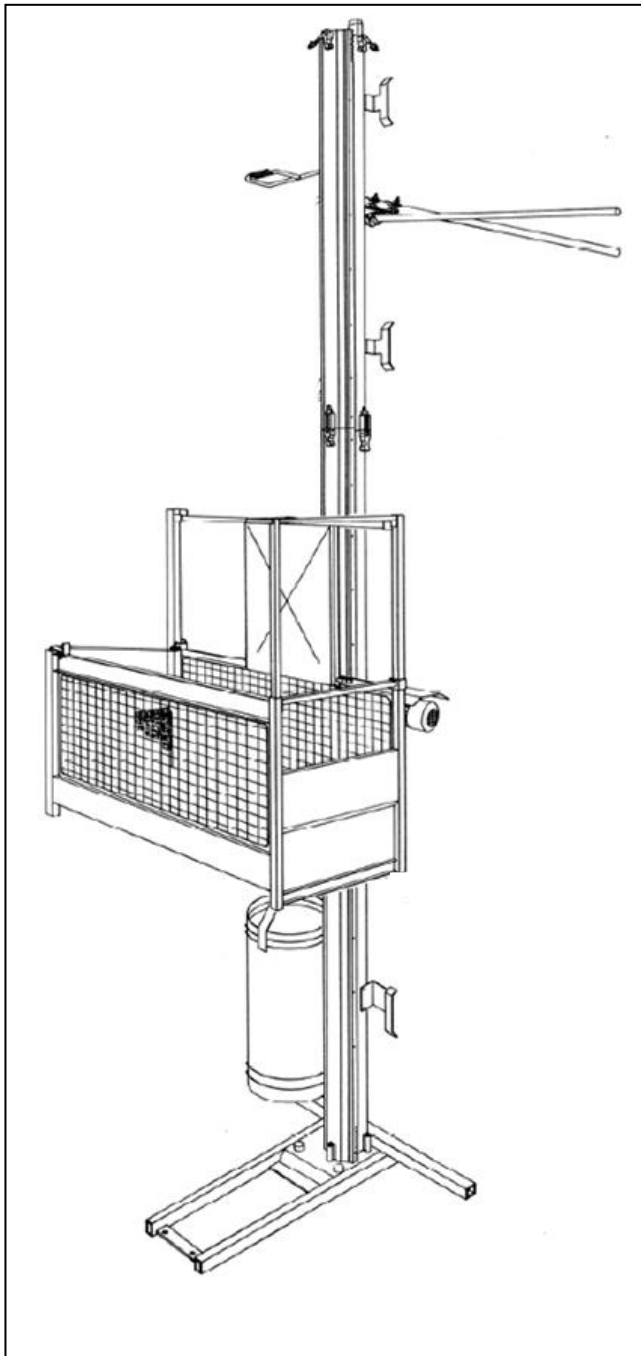

A versatile rack and pinion goods hoist with applications throughout the construction, renovation and building trades.

The hoist is operated by a simple push-button control. Each unit is equipped with an overload sensor for safety and a hinged loading ramp which is electrically interlocked.

The standard configuration of the platform for unloading has the platform swivel 90° into the scaffold or face of the building. Alternatively the platform can be supplied with a double-entry cage (straight-through) upon request.

TECHNICAL SPECIFICATIONS

Max carrying capacity	300kg
Average lifting speed	20m/min
Power requirement	Single phase 240 volt 16 amp
Max. working height	50m
Platform dimensions	1.40 x 0.75 x 1.10/1.80m
Weight of base unit	300kg
Weight of mast section	25kg